



# SBF -3920Series

Low Ohmic EB Welded SMD Precision Resistor

### Features

- 5 Watts Permanent Power
- Constant Current up to 100 amps (0.5mΩ)
- High Conductivity Copper Connectors
- Excellent Long Term Stability
- High Application Temperature Range -55°C to +170°C
- Max. Solder Temperature up to 350°C / 30Sec
- Flame Resistant
- Solid Metal Construction
- RoHS and REACH Certified
- AEC-Q200 Compliant

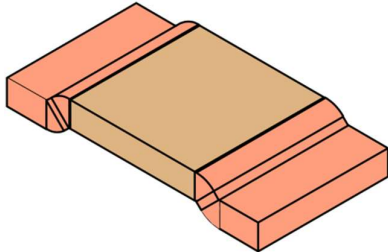

### Applications

- Current Sensing / Feedback
- Automotive Applications
- Power Modules
- Frequency Convertors
- Inverters
- Low Inductance Applications



Technical Data		
Resistance Values	0.2, 0.3, 0.5, 0.7, 1, 1.5, 2, 2.5, 3, 4, 5	(mΩ)
Tolerance	1, 5	(%)
TCR - Temperature Coefficient (Resistive Alloy)	<± 20(Copper Manganese Alloys), < -35 (Aluchrom Alloy)	(ppm/K)
Applicable Temperature Range	-55 to +170	°C
Load Capacity	See Table 2	-
Inductance	<3	nH
Stability Deviation	< 0.5 after 2000 Hours, T <sub>t</sub> * = 100°C	%
	< 1.0 after 2000 Hours, T <sub>t</sub> * = 130°C	%

\* T<sub>t</sub> = Terminal Temperature

Table 1

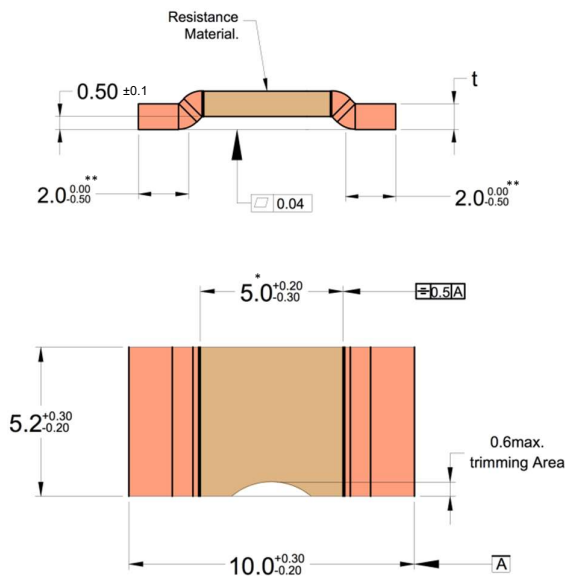

All dimensions are in mm, See table 2 for thickness.  
 \*\* this tolerance applies to t≤0.68 mm, for t>0.68 mm applicable tolerance is +0/-0.8  
 \* For SBF(S)-CM1-R0002, this dimension is 3.5 + 0.2, -0.3



# SBF - 3920 Series

Low Ohmic EB Welded SMD Precision Resistor

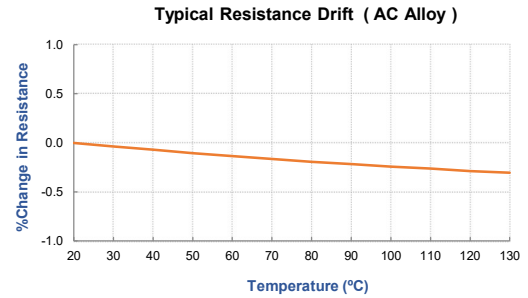
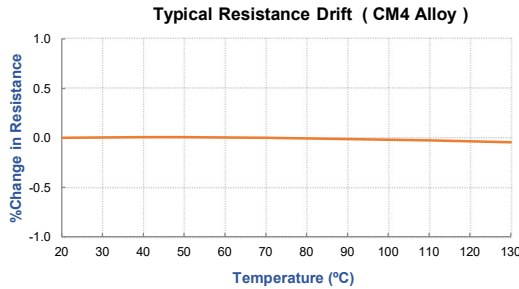
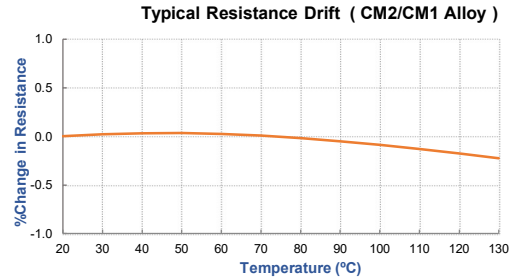
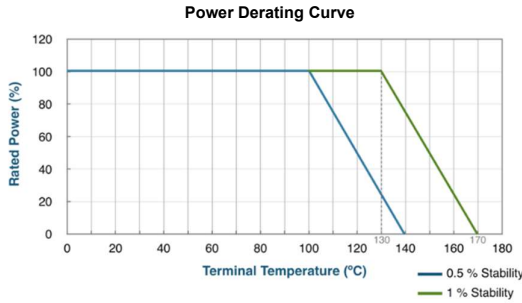

## Performance:

Type of Test	Reference STD	Test Specifications	Acceptance Criteria
High Temperature Exposure	MIL-STD-202 Method 108	1000Hrs. @ T=170°C.Unpowered.	$\Delta R$ +/-1%
Temperature Cycling	JESD22 Method JA-104	-55°C to 150°C, 1000Cycles, 30Mins at each extreme	$\Delta R$ +/-0.5%
Biased Humidity	MIL-STD-202 Method 103	85°C & 85RH with 10% operating power, 1000Hrs	$\Delta R$ +/-0.5%
Operational Life	MIL-STD-202 Method 108	125°C at rated power,1000Hrs	$\Delta R$ +/-1%
External Visual	MIL-STD-883 Method 2009	Visual inspection	Visual
Physical Dimension	JESD22 Method JB-100	Dimensional inspection as per SBCL Specifications	Shall confirm within tolerance limits
Resistance to Solvents	MIL-STD-202 Method 215	Clean with Aqueous chemical	Marking shall be legible
Mechanical Shock	MIL-STD-202 Method 213	100g for 6ms, Half sine	$\Delta R$ +/-0.2%
Vibration	MIL-STD-202 Method 204	5g for 20Mins, 12 cycles each of 3 orientations.10-2000Hz	$\Delta R$ +/-0.2%
Resistance to Soldering Heat	MIL-STD-202 Method 210	Solder Temp. 260°C, Time 10Secs	$\Delta R$ +/-0.5%
Solderability	J-STD-002	As per J-STD-002	>95% Coverage in 10x Magnification
Electrical Characterization	User Spec.	Resistance as defined	Shall confirm within tolerance limits
Short Time Over Load	--	5x Rated Power for 5Secs	$\Delta R$ +/-1%
Low Temperature Storage	--	-65°C for 24Hrs	$\Delta R$ +/-0.2%



# SBF - 3920 Series

Low Ohmic EB Welded SMD Precision Resistor

Type	Resistance Value (mΩ)	Material	t+/- 0.10 (mm)	TCR (ppm)	P <sub>70°C</sub> (W) At Ambient	P <sub>100°C</sub> (W) At Ambient
SBF-CM4-R0002	0.2	Copper Manganese Tin Alloy	1.42	<100	12	5
SBF(S)-CM1-R0002	0.2	Copper Manganese Alloy	1.30	<200	12	5
SBF-CM2-R0003	0.3	Copper Manganese Alloy	1.42	<150	10	5
SBF-CM2-R0005	0.5	Copper Manganese Alloy	0.84	<70	10	5
SBF-CM2-R0007	0.7	Copper Manganese Alloy	0.60	<60	8	5
SBF-CM2-R001	1.0	Copper Manganese Alloy	0.42	< 50	7	4
SBF-AC-R001	1.0	Aluchrom Alloy	1.36	< 50	8	5
SBF-AC-R0015	1.5	Aluchrom Alloy	0.91	< 50	7	4.5
SBF-AC-R002	2.0	Aluchrom Alloy	0.68	< 50	6	4
SBF-AC-R0025	2.5	Aluchrom Alloy	0.54	< 50	5	3.5
SBF-AC-R003	3.0	Aluchrom Alloy	0.45	< 50	5	3
SBF-AC-R004	4.0	Aluchrom Alloy	0.34	< 50	5	3
SBF-AC-R005	5.0	Aluchrom Alloy	0.27	< 50	3	2

Table 2

Reel Information	
Reference Standard	DIN EN 60286-3
Width of Reel	16 mm
Number of parts per Reel	3000 pcs

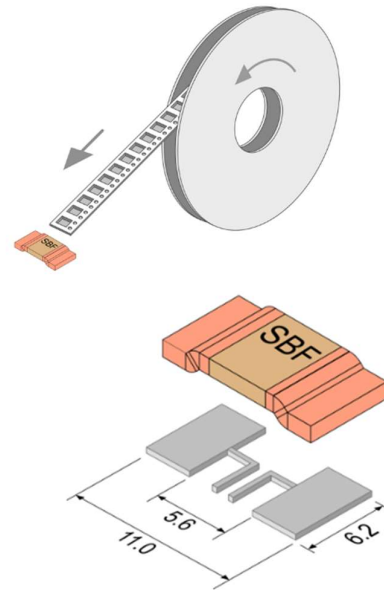
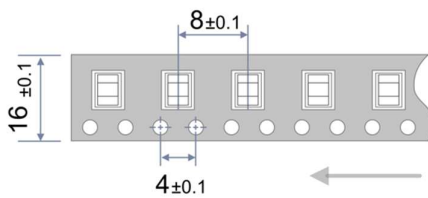

Proposed PCB Layout

**Note:**

- 1) Recommended Solder Reflow Profile:

<http://www.shivalikbimetals.com/SRP-01.pdf>



# SBF - 3920 Series

Low Ohmic EB Welded SMD Precision Resistor

### Example of Ordering Code

#### SBF-CM2-R0005-1-TR

