

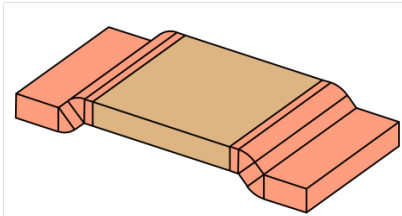

SBA -2512 Series

Low Ohmic EB Welded SMD Precision Resistor



Features

- 3-Watts Permanent Power (0.3 to 2 mΩ)
- Constant Current up to 77 amps (0.5 mΩ)
- High Conductivity Copper Connectors
- Excellent Long Term Stability
- High Application Temperature Range -55°C to +170°C
- Max. Solder Temperature up to 350°C / 30Sec
- Flame Resistant
- Solid Metal Construction
- RoHS and REACH Compliant
- AEC-Q200 Qualified

Applications

- Current Sensing/ Feedback
- Automotive Applications
- Power Modules
- Frequency Convertors
- Inverters
- Low Inductance Applications



Technical Data		
Resistance Values	0,0.3,0.5, 1, 1.3, 2, 3, 4, 5, 6.8, 10	(mΩ)
Tolerance	1, 2, 5	(%)
TCR - Temperature Coefficient (Resistive Alloy)	<±10 (Copper Manganese Alloys), < -25 (Aluchrom Alloy)	(ppm/K)
Applicable Temperature Range	-55 to +170	°C
Load Capacity	See Table 2	-
Inductance	<2	nH
Stability Deviation	< 0.5 after 2000 Hours, T _t *= 110°C	%
* T _t = Terminal Temperature	< 1.0 after 2000 Hours, T _t *= 140°C	%

Table 1

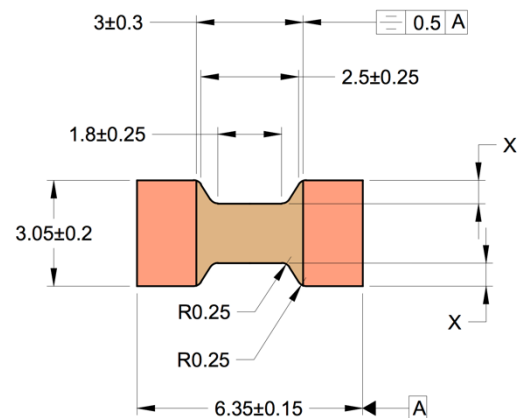
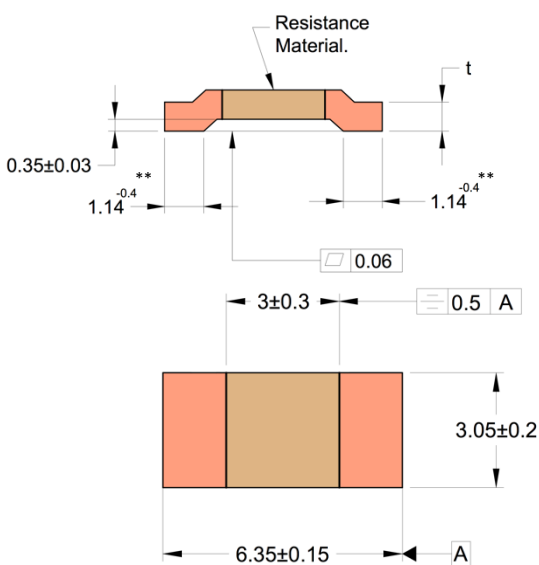

Dimensions are in mm. See table 2 for thickness.

** Tolerance for t≤0.67 mm, for t>0.67 mm applicable tolerance is +0/-0.7

5 to 10 mΩ



SBA – 2512 Series

Low Ohmic EB Welded SMD Precision Resistor

P/P_{NOM} Power Derating Curve

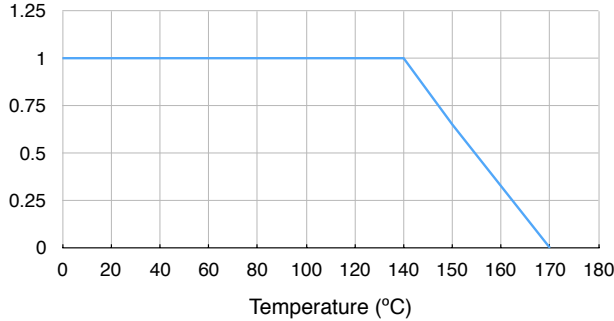

Resistance Change vs Temperature

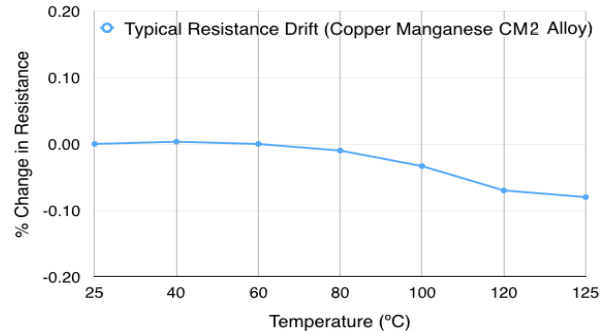

Resistance Change vs Temperature

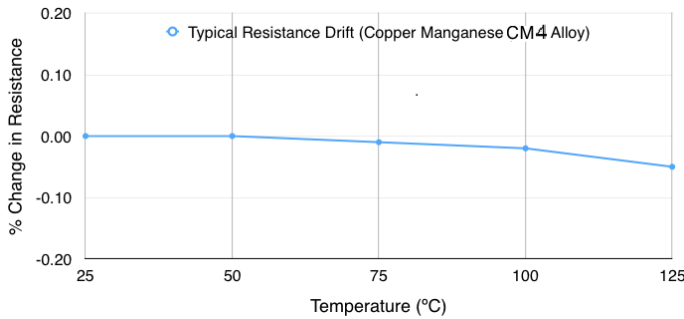

Resistance Change vs Temperature

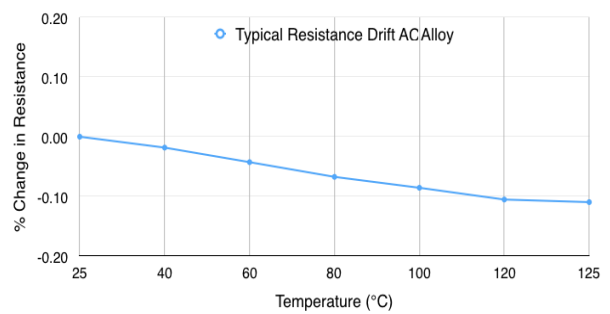

Performance:

Type of Test	Reference STD	Test Specifications	Acceptance Criteria
High Temperature Exposure	MIL-STD-202 Method 108	1000 hrs. @ T=170°C.Unpowered.	ΔR +/-1%
Temperature Cycling	JESD22 Method JA-104	-55°C to 150°C, 1000Cycles, 30 Minutes at each extreme	ΔR +/-0.5%
Biased Humidity	MIL-STD-202 Method 103	85°C & 85RH with 10% operating power, 1000 hrs.	ΔR +/-0.5%
Operational Life	MIL-STD-202 Method 108	125°C at rated power, 1000 hrs.	ΔR +/-1%
External Visual	MIL-STD-883 Method 2009	Visual inspection	Visual
Physical Dimension	JESD22 Method JB-100	Dimensional inspection as per SBCL Specifications	Shall confirm within tolerance limits
Resistance to Solvents	MIL-STD-202 Method 215	Clean with Aqueous chemical	Marking shall be legible
Mechanical Shock	MIL-STD-202 Method 213	100g for 6ms, Half sine	ΔR +/-0.2%
Vibration	MIL-STD-202 Method 204	5g for 20 minutes, 12 cycles each of 3 orientations.10-2000Hz	ΔR +/-0.2%
Resistance to Soldering Heat	MIL-STD-202 Method 210	Solder Temp. 260°C, Time 10 seconds	ΔR +/-0.5%
Solderability	J-STD-002	As per J-STD-002	>95% Coverage in 10x Magnification
Electrical Characterization	User Spec.	Resistance as defined	Shall confirm within tolerance limits
Short Time Over Load	--	5x Rated Power for 5 seconds	ΔR +/-1%
Low Temperature Storage	--	-65°C for 24 hrs.	ΔR +/-0.2%



SBA – 2512 Series

Low Ohmic EB Welded SMD Precision Resistor

Type	Resistance Value (mΩ)	Material	R _{thi} (°C/W)	t +/- 0.1 mm	TCR (ppm)	P _{100°C} (W)	P _{70°C} (W)
SBA-Cu-R000	0.0	Tin Plated Copper	-	0.42	-	-	
SBA-CM4-R0003	0.3	Copper Manganese Alloy	4	0.95	< 100	3	6
SBA-CM2-R0005	0.5	Copper Manganese Alloy	7	0.85	< 75	3	6
SBA-CM2-R001	1.0	Copper Manganese Alloy	12	0.42	< 50	3	5
SBA-CM2-R0013	1.3	Copper Manganese Alloy	15	0.33	< 50	3	5
SBA-AC-R002	2.0	Aluchrom Alloy	17	0.67	< 50	3	5
SBA-AC-R003	3.0	Aluchrom Alloy	20	0.45	< 50	2	4
SBA-AC-R004	4.0	Aluchrom Alloy	25	0.33	< 50	2	3
SBA-AC-R005	5.0	Aluchrom Alloy	40	0.33	< 50	1.5	2.5
SBA-AC-R0068	6.8	Aluchrom Alloy	55	0.33	< 50	1.5	2
SBA-AC-R010	10	Aluchrom Alloy	65	0.33	< 50	1	1.5

Table 2

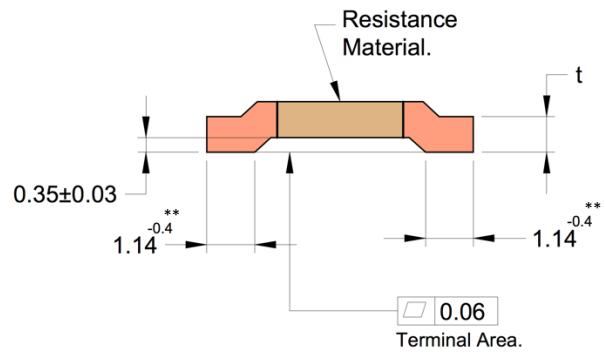
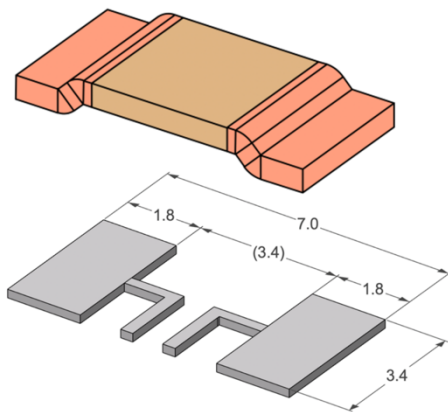

** Tolerance for t ≤ 0.67 mm, for t > 0.67 mm applicable tolerance is +0/-0.7

Solder Pad Layout

Note:

- Recommended Solder Reflow Profile:

<http://www.shivalikbimetals.com/SRP-01.pdf>



SBA – 2512 Series

Low Ohmic EB Welded SMD Precision Resistor

Reel Information	
Reference Standard	DIN EN 60286-3
Width of Reel	12 mm
Number of parts per Reel	5000 pcs

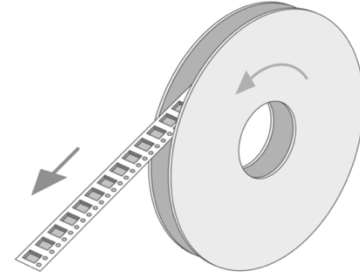

Example of Ordering Code

SBA-CM2-R0005-1-TR

